

SERIE CA-CA(N)

TABELLA DI PRESTAZIONI IDRAULICHE A 50 Hz, 2 POLI

POMPA TIPO	POTENZA NOMINALE		Q = PORTATA												
			l/min	0	30	40	50	60	70	80	100	120	150	180	210
	kW	HP	m ³ /h	0	1,8	2,4	3	3,6	4,2	4,8	6	7,2	9	10,8	12,6
H = PREVALENZA TOTALE IN METRI COLONNA ACQUA															
CA(M) 70/33	0,75	1	42,9	38,8	36,9	34,6	31,7	28,2	23,9						
CA(M) 70/34	0,9	1,2	48,8	45,1	43,2	40,7	37,7	34,0	29,5						
CA(M) 70/45	1,1	1,5	56,2	52,0	49,8	47,1	43,9	39,9	35,3						
CA(M) 120/33	1,1	1,5	44,3			39,1	37,8	36,4	34,8	31,4	27,6	21,0			
CA(M) 120/35	1,5	2	54,0			49,4	48,1	46,6	44,9	41,2	36,8	29,3			
CA(M) 120/55	2,2	3	63,8			59,6	58,2	56,6	54,8	50,6	45,7	37,1			
CA(M) 200/33	1,85	2,5	43,2			41,8	41,2	40,6	39,9	38,3	36,4	33,2	29,5	25,5	
CA(M) 200/35	2,2	3	53,5			52,4	51,9	51,4	50,7	49,2	47,5	44,3	40,6	36,5	
CA 200/55	3	4	62,6			61,0	60,6	60,1	59,5	58,2	56,6	53,8	50,4	46,2	

ca-2p50_d_th

SERIE CA-CA(N)

DATI ELETTRICI A 50 Hz, 2 POLI

POMPA TIPO MONOF.	MOTORE TIPO	POTENZA	CORRENTE	CONDENS.	POMPA TIPO TRIFASE	MOTORE TIPO	POTENZA	CORRENTE	CORRENTE
		ASSORB.*	ASSORB.*				ASSORB.*	ASSORB.*	
		kW	220-240 V A	μF / 450 V			kW	220-240 V A	380-415 V A
CAM70/33	SM71CA/1075	1,15	5,16	20	CA70/33	SM80CA/307PE	1,06	3,24	1,87
CAM70/34	SM71CA/1095	1,39	6,22	25	CA70/34	SM80CA/311PE	1,28	4,10	2,37
CAM70/45	SM80CA/1115	1,76	7,92	30	CA70/45	SM80CA/311PE	1,63	4,90	2,83
CAM120/33	SM80CA/1115	1,67	7,53	30	CA120/33	SM80CA/311PE	1,54	4,69	2,71
CAM120/35	SM80CA/1155	2,18	9,87	40	CA120/35	SM80CA/315PE	2,01	6,11	3,53
CAM120/55	PLM90CA/1225	2,54	11,5	70	CA120/55	PLM90CA/322	2,55	8,05	4,65
CAM200/33	PLM90CA/1225	2,29	10,4	70	CA200/33	PLM90CA/322	2,26	7,47	4,31
CAM200/35	PLM90CA/1225	2,94	12,6	70	CA200/35	PLM90CA/322	3,02	9,08	5,24
-	-	-	-	-	CA200/55	PLM90CA/330	3,51	10,7	6,18

*Valori massimi nel campo di funzionamento

ca-2p50_f_te

SERIE CA-CA(N) DIMENSIONI E PESI A 50 Hz, 2 POLI

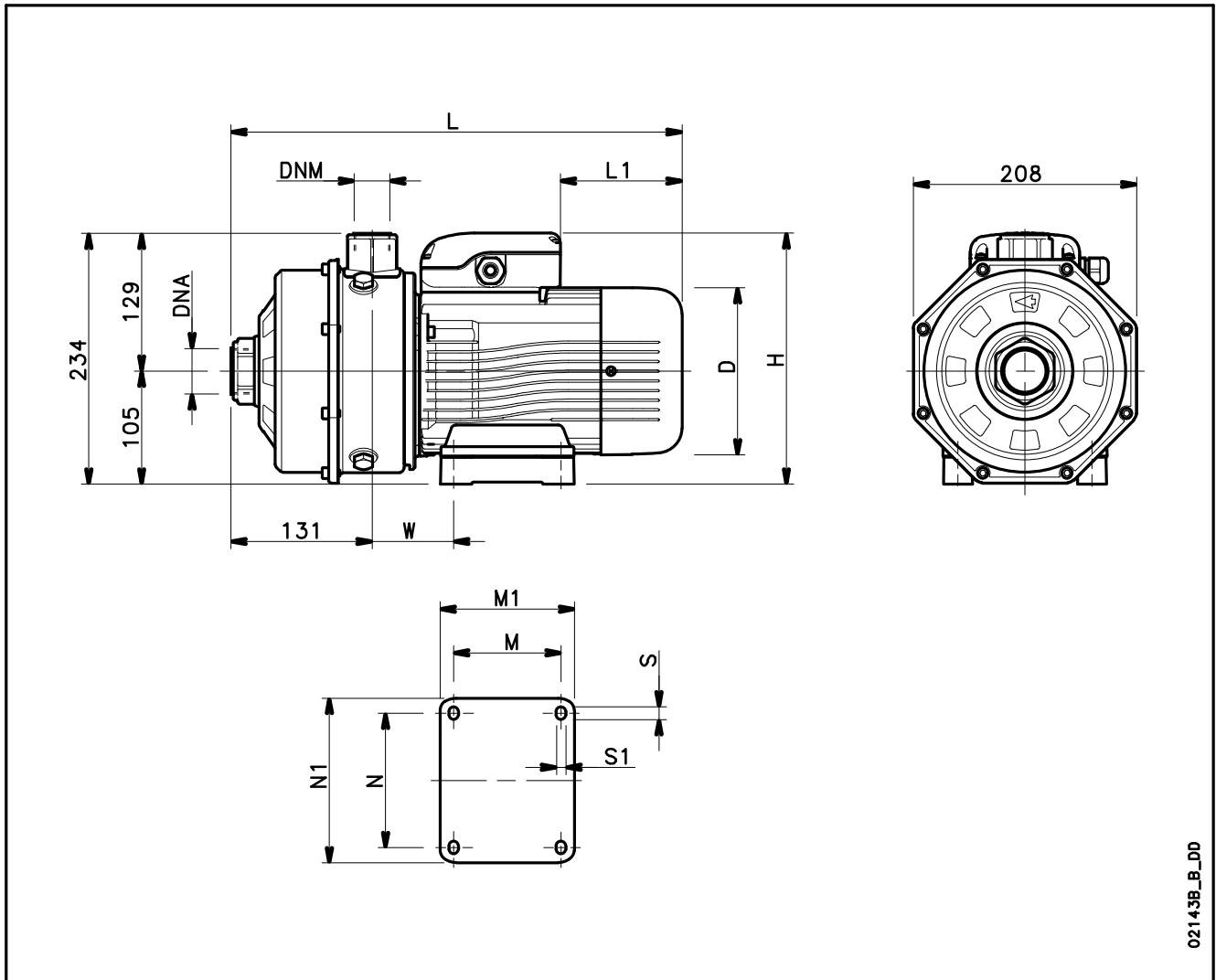

021*3B_B_DD

POMPA TIPO	DIMENSIONI (mm)											DNA	DNM	PESO kg
	D	H	L	L1	M	M1	N	N1	S	S1	W			
CAM 70/33/B	140	226	383	76	90	113	112	135	12	7	66	Rp 1¼	Rp 1	15
CAM 70/34/B	140	235	383	31	90	113	112	135	12	7	66	Rp 1¼	Rp 1	15,8
CAM 70/45/B	156	242	420	69	100	125	125	153	12	9	76	Rp 1¼	Rp 1	18,5
CAM 120/33/B	156	242	420	69	100	125	125	153	12	9	76	Rp 1¼	Rp 1	18,4
CAM 120/35/B	156	242	420	69	100	125	125	153	12	9	76	Rp 1¼	Rp 1	20,2
CAM 120/55/P	174	256	454	84	125	155	140	170	13	10	98	Rp 1¼	Rp 1	27
CAM 200/33/P	174	256	454	84	125	155	140	170	13	10	98	Rp 1½	Rp 1	27
CAM 200/35/P	174	256	454	84	125	155	140	170	13	10	98	Rp 1½	Rp 1	27
CA 70/33/D	155	234	420	114	100	125	125	153	12	9	76	Rp 1¼	Rp 1	16,7
CA 70/34/D	155	234	420	114	100	125	125	153	12	9	76	Rp 1¼	Rp 1	17,4
CA 70/45/D	155	234	420	114	100	125	125	153	12	9	76	Rp 1¼	Rp 1	18,7
CA 120/33/D	155	234	420	114	100	125	125	153	12	9	76	Rp 1¼	Rp 1	18,7
CA120/35/D	155	234	420	114	100	125	125	153	12	9	76	Rp 1¼	Rp 1	20,4
CA 120/55/P	174	239	454	172	125	155	140	170	13	10	98	Rp 1¼	Rp 1	25
CA 200/33/P	174	239	454	172	125	155	140	170	13	10	98	Rp 1½	Rp 1	25
CA 200/35/P	174	239	454	172	125	155	140	170	13	10	98	Rp 1½	Rp 1	25
CA 200/55/P	174	239	454	172	125	155	140	170	13	10	98	Rp 1½	Rp 1	27

ca-2p50_L_td